



VMMOB-19 Series

19" Daylight Viewable Industrial-Grade Monitors

- 19" Optically Bonded LCD Monitors; Ideal for Use in Bright Daylight
- Protective Anti-Reflective Glass
- 450 Nits Brightness
- Operating Temperature: -22° to + 185° F
- TRU-Tuff Ensures Maximum Shock & Vibration Resistance
- Auto Re-Start After Power Loss
- Lockable On-Screen Display Controls
- Can Be Customized to Meet Your Needs
- 3-Year Warranty

The VMMOB-19 Series are Optically-Bonded LCD monitors, designed to dramatically improve viewability in bright daylight and other high ambient light conditions. The optical bonding process injects an optical-grade epoxy resin between the surface of the LCD panel and the outer protective glass, eliminating the air gap between the two. The outer glass surface has an Anti-Reflective coating. The net result is a dramatic reduction in unwanted reflections, and a tremendous increase in contrast ratio, making the monitor ideal for use in outdoor daylight or brightly lit areas. Optical Bonding also provides other benefits such as increased ruggedness and durability, prevents internal condensation or fogging, and makes the outer glass shatter-proof.

The VMMOB-19 Series Daylight Viewable LCD monitors are built with industrial-grade components, and receive our exclusive TRU-TUFF treatment. The TRU-Tuff process includes: RTV silicone on all connections and critical components; all wires are dressed, tie-wrapped and secured; and ThreadLock on all screws. This ensures maximum shock and vibration resistance. These monitors are ideal for wide range of demanding applications including industrial, military, law enforcement, transportation, aviation, marine, inspection, cranes, oceanic, and entertainment.

Specifications

MODEL	VMMOB-19B	VMMOB-19C	VMMOB-19C-24	VMMOB-19B-24M
LCD Panel	19" Color LCD (LED Backlights)			
Display Resolution	1280 x 1024 (SXGA)			
Viewable Area	14.81" (W) x 11.85" (H) (376.17 x 300.98 mm)			
Pixel Pitch	0.294mm x 0.294mm			
Display Colors	16.7 Million			
Aspect Ratio	4:3 (5:4)			
Brightness	450 nits			
Contrast Ratio	1000:1			
Viewing Angle	170° (H) x 160° (V)			
Response Time	5 msec Trf			
Control	OSD (On-Screen Display) via Front Panel Pushbuttons			
Video Inputs	VGA, Composite BNC Loop-Thru; NTSC/PAL	VGA, DVI-D		VGA, Composite BNC Loop-Thru; NTSC/PAL
Analog Video Outputs	1 BNC Input/1 Output	—		1 BNC Input/1 Output
Audio	Rear Speakers			—
Power Requirement	12 VDC (2.1 mm Barrel Plug); 90-240 VAC via Included Power Brick		24 VDC (2.5mm Barrel Plug)	
Power Consumption	37 Watts			
Enclosure	ABS			Powder-Coated Steel
Mounting	Rear 75 x 75mm Rear VESA Mount Holes (Optional Tabletop Base)			100 x 100mm Vesa Holes
Operating Temperature	-22° to +185° F (-30° to 85° C)			
Operating Altitude	To 18,000 Ft.			
Humidity	5-90% RH			
Shock	50 G (20 msec, 1/2 sine)			
Vibration	1.5G RMS 10-200 HZ			
Dimensions	16.59" (W) x 13.80" (H) x 1.89" (D) (421.4 x 350.5 x 48.1 mm)			15.79" (W) x 13.19" (H) x 1.87" (D) (401 x 334.9 x 47.5mm)
Weight	9.6 lb (4.4 kg)			11.1 lb (5 kg)
Warranty	3-Years			

VMMOB-19 Series

19" Daylight Viewable Industrial-Grade Monitors LCD Monitors

Dimensions for ABS Enclosure:

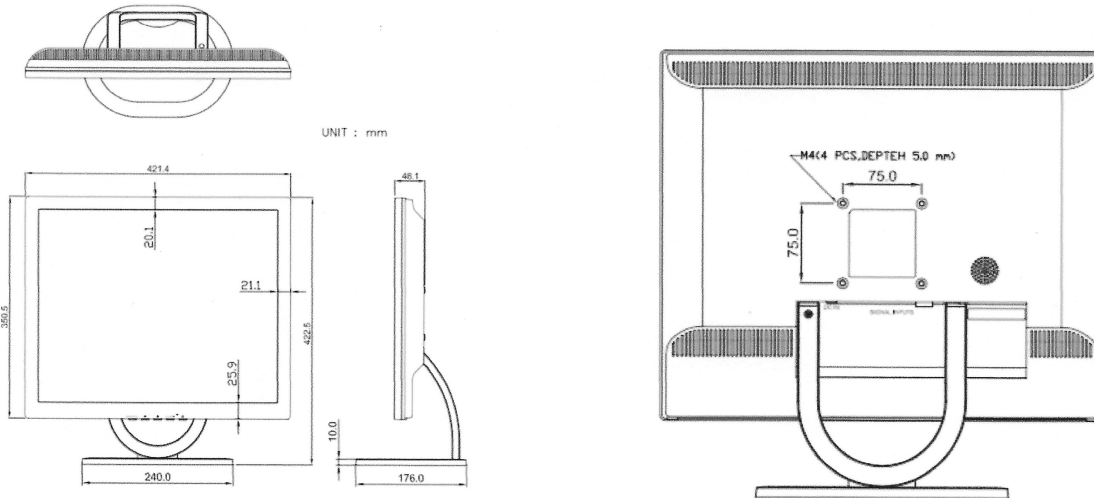

Standard Accessories:

- 90-240 VAC Power Supply (Except -24M Model)
- VGA Cable (Except -24M Model)
- Audio Cable (Except -24M Model)

Available Options:

- Tabletop Stand
- Direct 110 VAC Operation (no external power brick)
- S-Video Input
- Panel Mount
- 11-36 VDC Operation
- Touch Screen
- Open-Frame Configuration
- Private Label
- Bolt-On Rack-Mount Bracket
- Other Customer - Specific Modifications