

VL-SRMTP-19H

19" SUNLIGHT READABLE TOUCHSCREEN

- Projected Capacitive Touch Screen
- Produces Clear, Sharp Images Even in Direct, Bright Sunlight
- 1,000 nits Brightness
- IP65 Edge-to-Edge All-Glass Front Surface
- Anti-Glare Tempered Glass
- Waterproof Touch Sensor Allows Wet Finger Operation
- Automated Ambient Light Sensor



19" SUNLIGHT READABLE TOUCH SCREEN PANEL-MOUNT

The VL-SRMTP-19H is a 19" sunlight readable touch screen. This rugged 19" touch screen features 1,000 nits brightness, anti-glare glass and a 4:3 (5:4) aspect ratio.

SUNLIGHT READABLE TOUCH SCREEN WITH 1000 NITS BRIGHTNESS

The VL-SRMTP-19H is a 19" sunlight readable touch screen monitor. We feature 1000 nits screen brightness and a 4:3 aspect ratio on this model. We design this 19 bright touchscreen for indoor and outdoor use. Because of the high 1,000 nits brightness of the VL-SRMTP-19H monitors, they are perfect for any high ambient-light conditions. These weather proof touch screens utilize state-of-the-art LED backlights. 1,000 nits brightness is over 3 to 5 times brighter than standard brightness monitors. Standard LCD monitors offer only 200-300 nits brightness. We feature a protective Anti-Reflective glass over the LCD panel on this model.

RUGGED 19" TOUCHSCREENS

These 19" 1,000 nit touch screen displays are not only bright, but extremely rugged. Built with true industrial-grade components, these outdoor panel mount touchscreens receive our exclusive TRU-Tuff treatment. The TRU-Tuff process includes RTV silicone on all connections and critical components. We then dress all wires, tie-wrap and secure them.

Lastly, we apply ThreadLock to all screws. The durable steel enclosure will ensure maximum shock and vibration resistance. This IP65 touchscreen will easily withstand the elements outdoors.

The front face of this weatherproof touchscreen has a rating of IP65 Waterproof. It is impervious to liquids, rust and corrosion. Additionally, our VL-SRMTP-19H has a Zero Bezel / Bezel-Less enclosure, which has no raised bezel, frame, or edges on the front face. The enclosure design feature will enable you to flush-mount this touch screen into a panel, door, wall, cabinet or enclosure.

Projected Capacitive (P-CAP) touch is similar to Surface Capacitive, but it offers two primary advantages: in addition to a dry bare finger, the VL-SRMTP-19H can also be activated with wet fingers. A Projected Capacitive touch screen also enables multi-touch activation. For instance, this will allow up to 10 simultaneous touch points. It is one of the 5 most popular types of touch screens available.

OUR TECHNICAL EXPERTS ARE READY YOU HELP YOU FIND THE BEST OUTDOOR DISPLAY

See our full line-up of industrial-grade Sunlight Readable and Daylight Readable monitors. This highlights all of our high brightness monitors. You'll find the sunlight readable touch screens in all the sizes and configurations available. Our full

range of **waterproof** monitors and **touch screens** are available for any outdoor use. With over 200 LCD monitors and touch screens on our site, selecting the ideal weatherproof touch screen solution may be a bit overwhelming. To help narrow-down the choices, check out our **Advanced Search Tool**. For example, this enables you to filter by your own important features. For instance, you may view only **4:3 aspect ratio monitors**, **13 - 19 inch monitors**, or only **panel mount monitors**. TRU-Vu can provide modified or Custom OEM LCD Displays. Private Label Monitors are also an option if you have very specific requirements.

If you prefer, fill out a quick form with your requirements, and we will guide you to the proper models that will work best.

SPECIFICATIONS

	VL-SRMTP-19H
LCD Panel	19" Color LCD; LED Backlights
Touch Screen Type	Projected Capacitive
Touch Interface	USB
Resolution	1280 x 1024 (SXGA)
Viewing Area	14.88" (W) x 11.91" (H) (378 mm x 302.5 mm)
Pixel Pitch	0.294mm
Display Colors	16.7 M
Aspect Ratio	4:3 (5:4)
Brightness	1,000 nits
Ambient Light Sensor	Standard
Contrast Ratio	1,000:1
Viewing Angle	170° (H) x 160° (V)
Response Time	8 msec (Trf)
Video Input	VGA & HDMI
Power Requirement	12VDC / 90-240VAC via Included AC Adapter
Enclosure	Zero-Bezel/Painted Steel
Enclosure Rating	IP65 Front
Mounting	Rear VESA 75x75mm & 100 x 100mm Mounting Holes (optional L-Brackets available for flush-mounting)
Operating Temperature	32° to 122°F (0° to +50°C)
Dimensions	17.08" W x 14.11" H x 2.64" D (433.8mm W x 358.5mm H x 67.1mm D)

Note: Specifications subject to change without notice.

DIMENSIONS (MM)

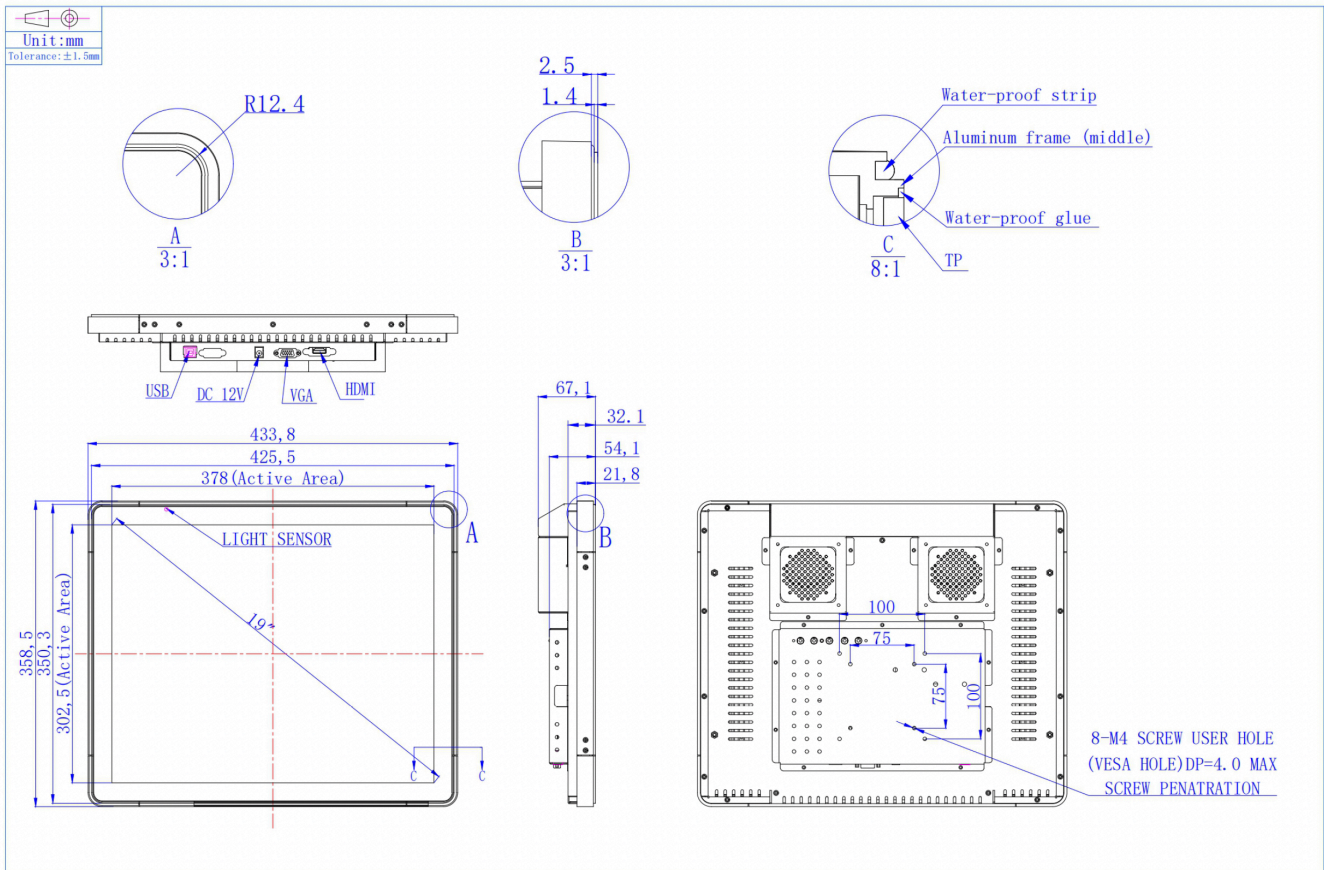

Standard Accessories:

- 90-240 VAC Power Supply
- VGA Cable
- HDMI Cable
- USB Cable

Available Options:

- Private Label