

SRMHOB-15B

15" Sunlight Readable Optically Bonded Monitors

- Produces Clear, Sharp Images Even in Direct Bright Sunlight
- 1,500 nits Brightness
- Optical Bonding For Increased Contrast Ratio
- *TRU-Tuff* Ensures Maximum Shock/Vibration Resistance
- Protective Anti-Glare Glass
- Auto Re-Start After Power Loss
- 3-Year Warranty



15" HIGH BRIGHTNESS LCD

The SRMHOB-15B are 15" high brightness LCD with the addition of Optical Bonding. They feature at least 1500 nits brightness and a 4:3 aspect ratio. We design the SRMHOB-15B 15" for use in direct sunlight. Consequently, they are also perfect for other high ambient-light conditions. They utilize state-of-the-art LED backlights. The models in this series produce at least 1,500 nits brightness. In contrast, this is over 3 to 5 times brighter than standard monitors. For example, standard monitors are only 200-300 nits brightness. The result is an amazingly bright screen. This will provide you with crystal-clear images, even with bright, direct sunlight on the face of the screen.

OPTICALLY BONDED DISPLAY



The SRMHOB-15B 15" high brightness LCD feature Anti-Reflective glass to protect the LCD panel. The glass also reduces unwanted surface reflections. However, the glass also introduces internal reflections. Therefore, TRU-Vu daylight readable monitors include **Optical Bonding**. This process injects an optical-grade resin into the air gap between the LCD panel and the glass. This completely fills the gap. The Optical Bonding eliminates the internal reflections. It also increases the contrast ratio, thereby greatly improving image quality. Optical Bonding also eliminates moisture and condensation beneath the glass.

RUGGED INDUSTRIAL MONITORS

These 15" 1500 nit displays are extremely rugged. For instance, we build them with true industrial-grade components. Furthermore, they receive our exclusive TRU-Tuff treatment. The TRU-Tuff process includes RTV silicone on all connections and critical components. Additionally, all wires are dressed, tie-wrapped and secured. Lastly, we apply ThreadLock to all screws. The rugged ABS enclosure ensures maximum shock and vibration resistance for this rugged 1500 nit monitor.

EXTREME OPERATING TEMPERATURE DISPLAYS

We design the SRMHOB-15" High Brightness Display Series to operate in nearly any environmental conditions. Whether in frigid conditions or blazing heat, these sunlight displays will survive and thrive. To clarify, these monitors will operate in temperatures down to 32°F (0°C). They will also withstand brutal heat. Moreover, operating temperatures go up to 150°F (60°C). The rugged powder coated steel enclosure assures these 15"high brightness displays will provide years of reliable imaging performance. Specifically, typical MTBF for these monitors is 50,000 hours.

OUR EXPERTS WILL HELP YOU FIND THE BEST 15" MONITOR FOR YOUR APPLICATION

Our 15" high brightness LCD 1500 nit monitors have been deployed in a wide range of demanding industries. For example, military, law enforcement, aviation and entertainment benefit. They are also deployed in inspection, marine cranes, and transportation. TRU-Vu monitors are backed by our full 3-Year Warranty. This ensures you of many years of reliable service.

See our full line-up of industrial-grade Sunlight Readable and Daylight Readable. This highlights all of our high brightness monitors. Additionally, you'll find the sunlight readable touch screens in all the sizes and configurations available. Shop by size 13" - 19" Monitors. TRU-Vu can provide modified or Custom OEM LCD Displays. Private Label Monitors are also an option if you have very specific requirements.

SPECIFICATIONS

	SRMHOB-15B
LCD Panel	15" Color LCD; LED Backlights
Resolution	1024 x 768 (XGA)
Viewable Area	11.97" (W) x 8.98" (H) (304.12 x 228.09 mm)
Pixel Pitch	0.297mm
Display Colors	16.2 M
Aspect Ratio	4:3
Brightness	1,500 nits
Contrast Ratio	900:1
Viewing Angle	170° (H) x 160° (V)
Response Time	8 msec Trf
Control	OSD (On-Screen Display) via Front Panel Pushbuttons
Vldeo Inputs	VGA, Composite (BNC Loop-Thru), NTSC/PAL Auto-Recognition
In/Output Impedance	75Ω / Auto Terminating Output
Audio	Optional Front Speaker
Power Requirement	12 VDC (2.1mm Barrel Plug); 90-240 VAC via Included Power Brick
Power Consumption	40 Watts Peak, 30 Watts Continuous
Enclosure	ABS
Mounting	Included Tabletop Base or Via 75x75mm Rear VESA Mount Holes
Operating Temperature	+32° to +140° F (0° to +60° C)
Humidity	5-90% RH
Shock	50 G (20 msec, ½ sine)
Vibration	1.5G RMS 10-200 HZ
Dimensions	13.66" (W) x 10.87" (H) x 1.78" (D) (347 x 276 x 45.2 mm)
Weight	6.35 lbs. (2.88 kg)
Warranty	3 Years
Screen Treatment	Optically Bonded

Note: Specifications subject to change without notice.

DIMENSIONS (MM)

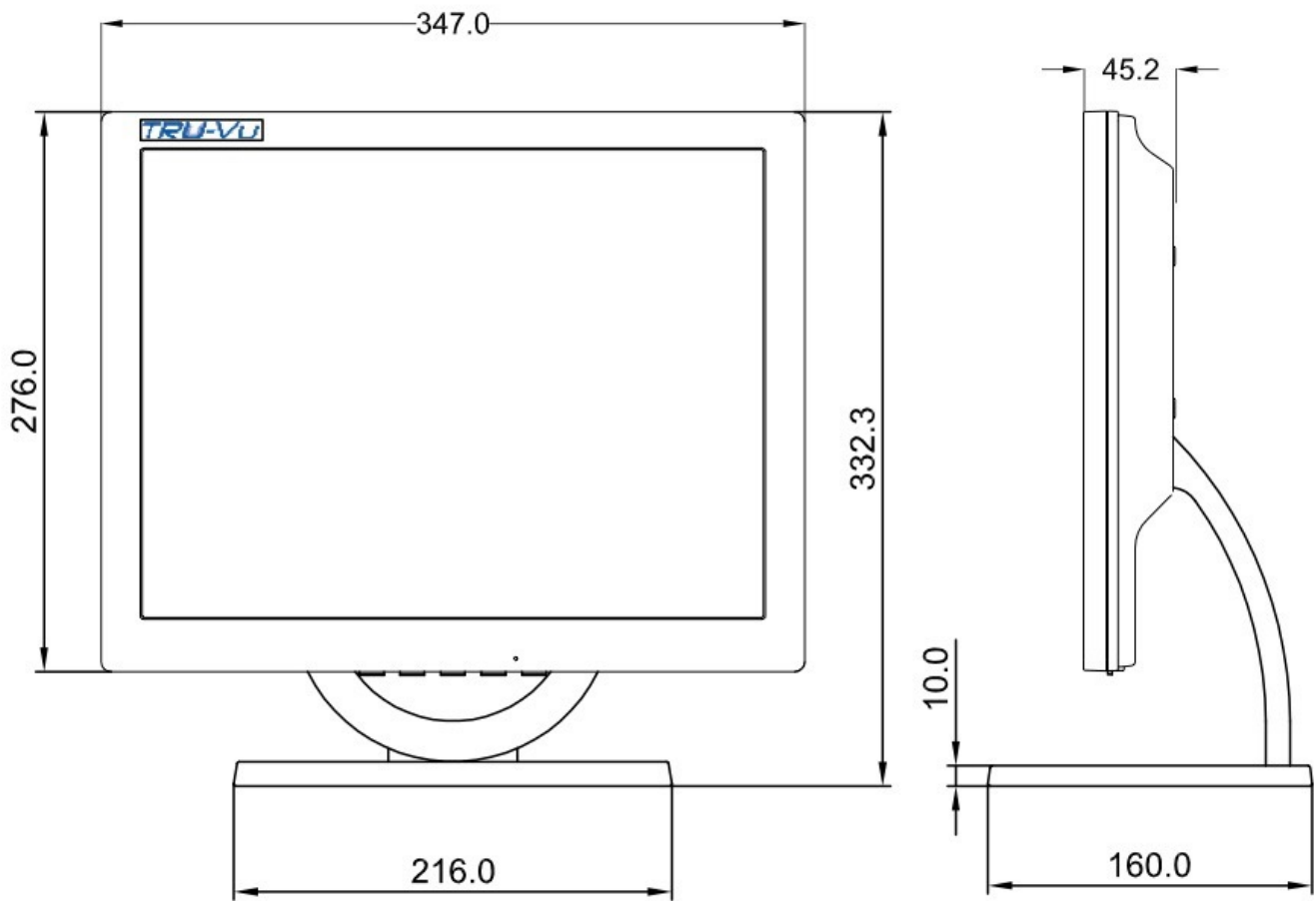

Standard Accessories:

- 90-240 VAC Power Brick (SRMHOB-15B Only)
- VGA Cable
- Tabletop Base (SRMHOB-15B Only)

Available Options:

- 9-36VDC Operation (SRMHOB-15B-36)
- Automated Ambient Light Sensor
- DVI Video Input
- S-Video Input (SRMHOB-15S)
- Tabletop Base (Optional on SRMHOB-15B-36, SRMHOB-15U-M)
- Dim-to-Black Hotkeys
- Panel Mount
- Steel Enclosure (SRMHOB-15U-M)
- Open-Frame Configuration
- Private Label
- Other Customer - Specific Modifications