



### SRMW-19U-24

#### 19" Waterproof Sunlight Readable LCD Monitor

- 1,000 nits Brightness
- Produces Clear, Sharp Images Even in Direct Bright Sunlight
- Waterproof NEMA 4X Stainless Steel Enclosure
- Protective Anti-Reflective Glass
- Automated Ambient Light Sensor
- Video Inputs: VGA, HDMI, Composite (BNC Loop-Thru)
- Operating Temperature: -22° F to +185° F (-30° to +85° C)
- Lockable On-Screen Display (OSD) Controls
- Auto Re-Start After Power Loss
- **TRU-Tuff** Ensures Maximum Shock/Vibration Resistance
- 3 Year Warranty

The SRMW-19U-24 sunlight readable monitors are designed to operate in direct bright sunlight, or in other high ambient-light conditions. They utilize state-of-the-art LED backlights to produce over 1,000 nits of brightness (vs. 250-300 nits for standard monitors). This results in amazingly bright, crystal-clear images, even with direct, bright sunlight on the face of the screen. The SRMW-19U-24 features a rugged NEMA 4X stainless steel panel-mount enclosure which can also be painted black. It is completely sealed and will withstand rain, snow, sleet, etc. These are ideal for outdoor use in a wide range of demanding applications including military, law enforcement, stadiums, amusement parks, advertising, transportation, marine, auto racing, oil and gas, inspection and other industries where viewability in direct sunlight is crucial.

All TRU-Vu industrial LCD monitors are specifically designed for use in demanding applications. Every TRU-Vu monitor utilizes industrial-grade components and high-end LCD panels not found in retail/consumer-grade monitors. This ensures superior image quality, improved performance and greater durability. Our 3-Year Warranty ensures you of reliable worry-free operation. Visit [www.TRU-VuMonitors.com](http://www.TRU-VuMonitors.com) for more details.

	<b>Specifications</b>
<b>MODEL</b>	<b>SRMW-19U-24</b>
<b>LCD Panel</b>	19" Color LCD: LED Backlights
<b>Display Resolution</b>	1280 x 1024 (SXGA)
<b>Viewable Area</b>	14.82" (W) x 11.85" (H) (376.32 x 301.06 mm)
<b>Pixel Pitch</b>	0.294 mm
<b>Display Colors</b>	16.7 M
<b>Aspect Ratio</b>	4:3 (5:4)
<b>Brightness</b>	1,000 nits
<b>Contrast Ratio</b>	1,000:1
<b>Backlight Adjustment</b>	Automatic Ambient Light Sensor
<b>Viewing Angle</b>	170° (H) x 160° (V)
<b>Response Time</b>	10 msec
<b>Control</b>	OSD via Rear Panel Pushbuttons
<b>Video Inputs</b>	VGA, HDMI, Composite (BNC Loop-Thru)
<b>Power Requirement</b>	12-24 VDC (optional 90-240 VAC Power Supply)
<b>Power Consumption</b>	40W
<b>Enclosure</b>	Stainless Steel
<b>Enclosure Rating</b>	NEMA 4X Waterproof (No Vent Holes)
<b>Mounting</b>	100 x 100 mm Rear VESA Mount Holes
<b>Operating Temperature</b>	-22° to +185° F (-30° to +85° C)
<b>Humidity</b>	5-90% RH
<b>Shock</b>	50G; 20 msec, half-sine
<b>Vibration</b>	1.5 G, (10-200Hz, P-P)
<b>Dimensions</b>	17.73" (W) x 14.36" (H) x 3.13"(D) (450.4 x 364.8 x 79.4mm)
<b>Weight</b>	18.19 lbs. (8.25 kg)
<b>Included Accessories</b>	Power Pigtail

## SRMW-19U-24

19" Waterproof Sunlight Readable LCD Monitor

### Dimensions:

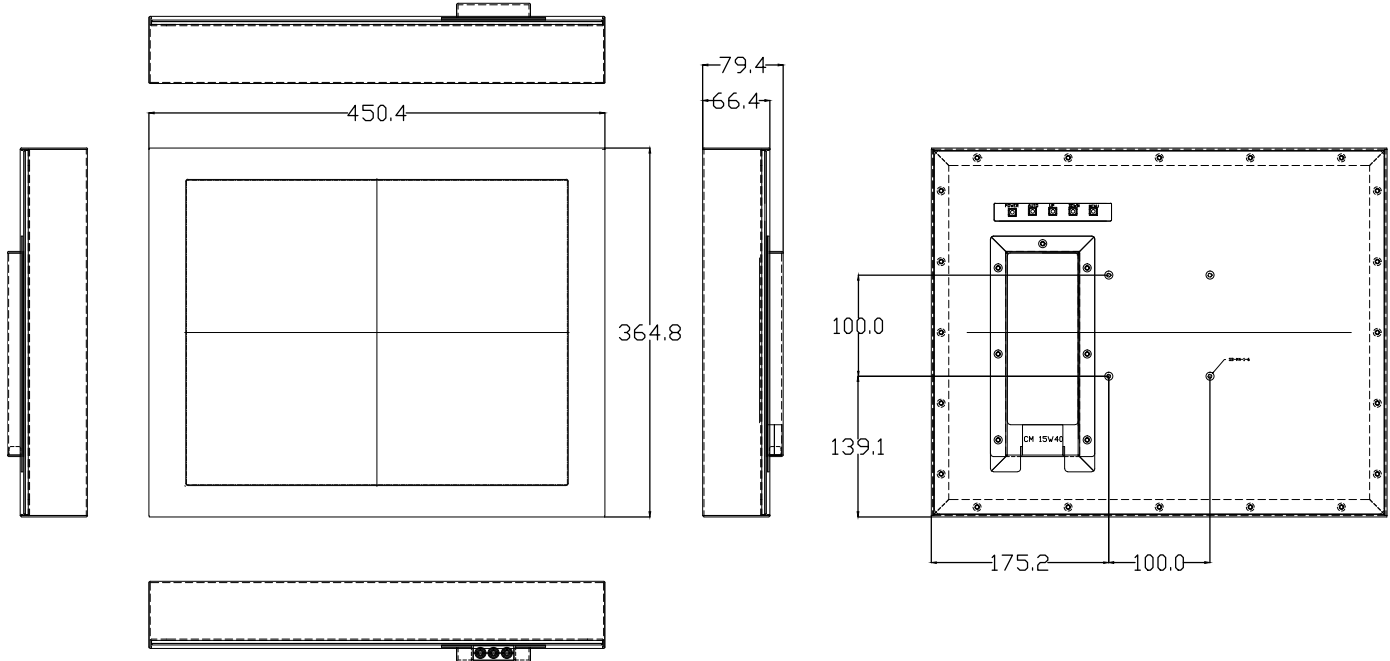

### Standard Accessories:

- Power Pigtail

### Available Options:

- Optical Bonding
- 90-240 VAC Power Supply (PS-200)
- Private Label
- Other Customer- Specific Modifications