



SRMX-18.5 Series

18.5" Sunlight Readable Industrial-Grade LCD Monitor

- 1,000 nits Brightness
- Produces Clear, Sharp Images Even in Direct Bright Sunlight
- Full HD Resolution: 1920 x 1080 (1080p/60)
- Ambient Light Sensor Adjusts Screen Brightness Automatically
- Lockable On-Screen Display (OSD) Controls
- Auto Re-Start After Power Loss
- **TRU-Tuff** Ensures Maximum Shock/Vibration Resistance
- Can Be Customized to Meet Your Needs
- 3 Year Warranty

The SRMX-18.5 Series Sunlight Readable monitors are designed to operate in direct bright sunlight, or in other high ambient-light conditions. They utilize state-of-the-art LED backlights to produce over 1,000 nits of brightness (vs. 250-300 nits for standard monitors). This results in amazingly bright, crystal-clear images, even with direct, bright sunlight on the face of the screen. The SRMX-18.5 Series Sunlight Readable monitors offer Full HD resolution; ideal for use in a wide range of demanding applications including industrial, law enforcement, aviation, marine, military, inspection, advertising, material handling (cranes) and transportation where viewability in direct bright sunlight is crucial.

All TRU-Vu industrial LCD monitors are specifically designed for use in demanding applications. Every TRU-Vu monitor utilizes industrial-grade components and high-end LCD panels not found in retail/consumer-grade monitors. This ensures superior image quality, improved performance and greater durability. Our 3-Year Warranty ensures you of reliable worry-free operation. Visit www.TRU-VuMonitors.com for more details.

Specifications		
MODEL	SRMX-18.5R	SRMX-18.5Z-24
LCD Panel	18.5" Color AHVA Panel; LED Backlights	
Resolution	1920 x 1080 (1080P/60)	
Backlights	LED	
Viewable Area	16.13" (W) x 9.07" (H) (409.8 x 230.4mm)	
Pixel Pitch	0.213mm	
Display Colors	16.7 M	
Aspect Ratio	16:9	
Brightness	1,000 nits	
Contrast Ratio	1,000:1	
Viewing Angle	178° (H) x 178° (V)	
Response Time	20 msec	
Control	OSD (On-Screen Display) via Rear Pushbuttons	
Video Inputs	VGA, HDMI, DisplayPort	VGA, HDMI, HD-SDI Loop-Thru, Composite (BNC Loop-Thru)
Audio	Rear Speakers	optional
Power Requirement	12-24 VDC / 90-240 VAC	12-24 VDC
Power Consumption	45W @ 12VDC	
Enclosure	Powder Coated Steel	
Mounting	100x100mm Rear VESA Mount Holes	
Operating Temperature	-4° to +158° F (-20° to +70° C)	
Humidity	5-90% RH	
Shock	50 G (20 msec, ½ sine)	
Vibration	1.5G RMS 10-200 HZ	
Dimensions	435.4 x 276.3 x 46 mm (17.14" x 10.87" x 1.81")	
Weight	7.5 Lbs	

SRMX-18.5Z-24

18.5" Sunlight Readable Industrial Grade Monitor

Dimensions:

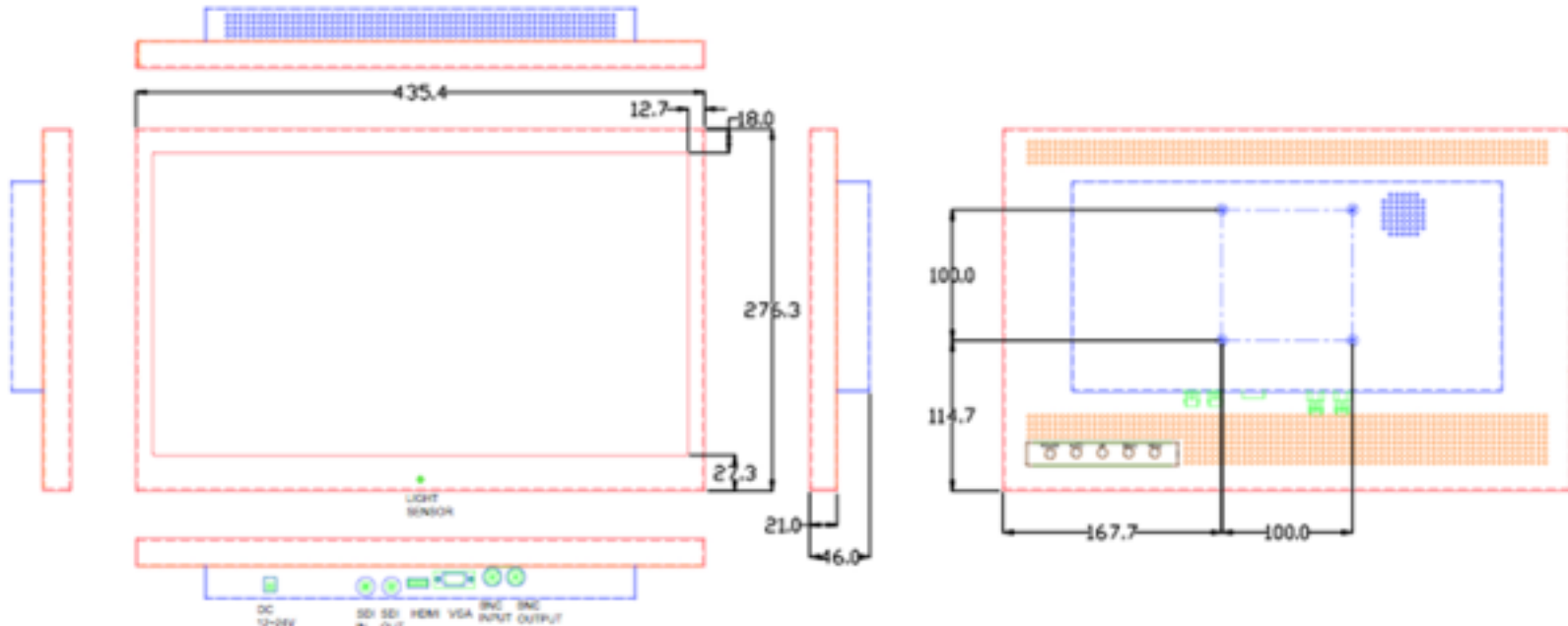

Standard Accessories:

- Tabletop Base (SRMX-18.5R Only)
- AC power Adapter (SRMX-18.5R Only)
- VGA Cable (SRMX-18.5R Only)
- HDMI Cable (SRMX-18.5R Only)
- Audio Cable (SRMX-18.5R Only)
- DC Power Pigtail (SRMX-18.5Z-24 Only)

Available Options:

- Stainless Steel NEMA 4X Waterproof Enclosure
- Touch Screen
- Aluminum Enclosure
- Wall Mount Brackets